

GAS VALVE RETROFIT KIT

Push Through Tube Heater Models

DESCRIPTION:

This kit is designed to replace existing Honeywell gas valves #VR8205P and #VR8205Q with White-Rodgers gas valves #36J23 and #36J58 respectively on push through tube heater models.

CAUTION:

This conversion kit is to be installed by an authorized distributor or other qualified agency in accordance with the manufacturer’s instructions and all codes and requirements of the authority having jurisdiction. Failure to follow instructions could result in serious injury, property damage or death. The qualified agency performing this work assumes responsibility for this conversion. **TURN OFF ALL ELECTRICAL AND GAS SUPPLIES TO THE CONTROL BEFORE MAKING THIS CONVERSION**

PACKAGE CONTAINS: (see page 5 for complete kit numbers)

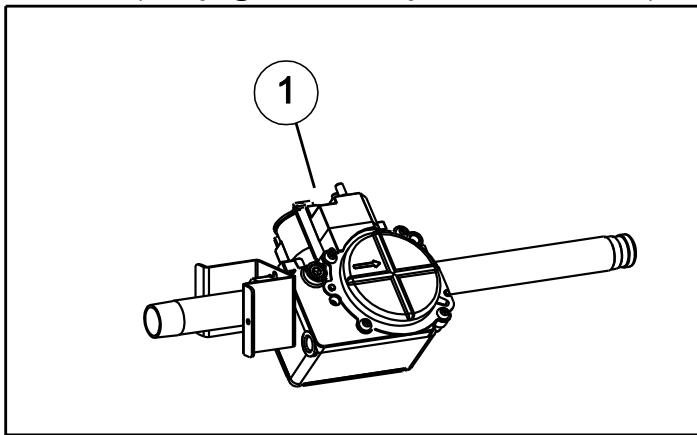

Item No.	Part No.	Description	Qty.	Push Burner Control (1-stage)	Push Burner Control (2-stage)
1	-see page 5-	Gas Valve and Manifold Assembly	1	YES	YES
2	44011260	Form, Gas Valve Retrofit (not shown)	1	YES	YES

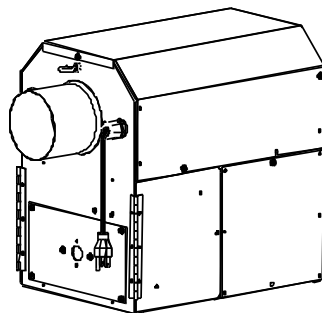

Push Burner Controls

INSTRUCTIONS: REPLACING GAS VALVE AND MANIFOLD ASSEMBLY – PUSH BURNERS

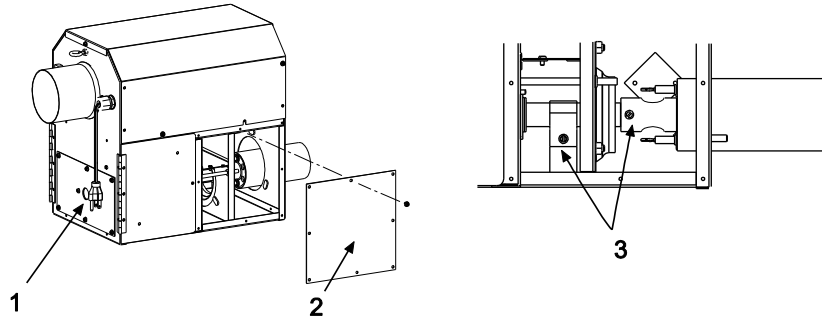

1. Disconnect electrical supply and gas connections at the heater.
2. Remove side access panel.
3. Loosen screws from manifold clamp and burner assembly.

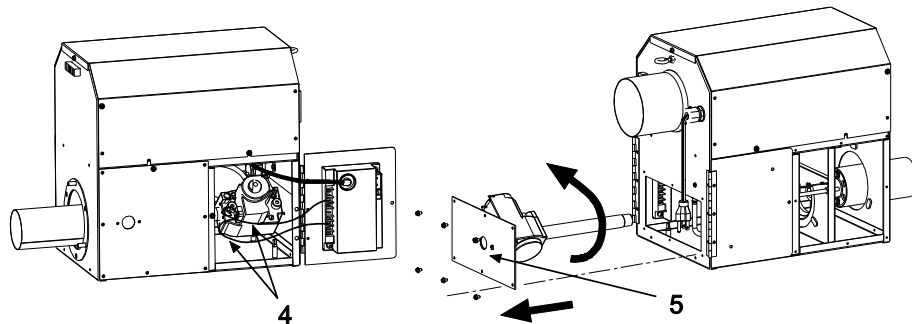

4. Open hinged access panel and disconnect wires from gas valve.
5. Remove (6) screws from end panel. Rotate gas valve and manifold assembly slightly counter-clockwise and slide out from housing.

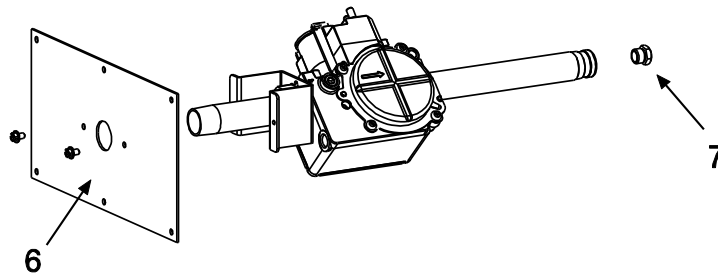

6. Remove valve holder plate from existing gas valve and manifold assembly. Re-attach plate to holder bracket of new gas valve and manifold assembly.
7. Remove main burner orifice from existing manifold pipe.
8. Re-attach new gas valve and manifold assembly in reverse order from above. Re-connect wires to gas valve. See below for connections

GAS VALVE WIRING CONNECTIONS – (1 AND 2 STAGE PUSH THROUGH CONTROLS ONLY)

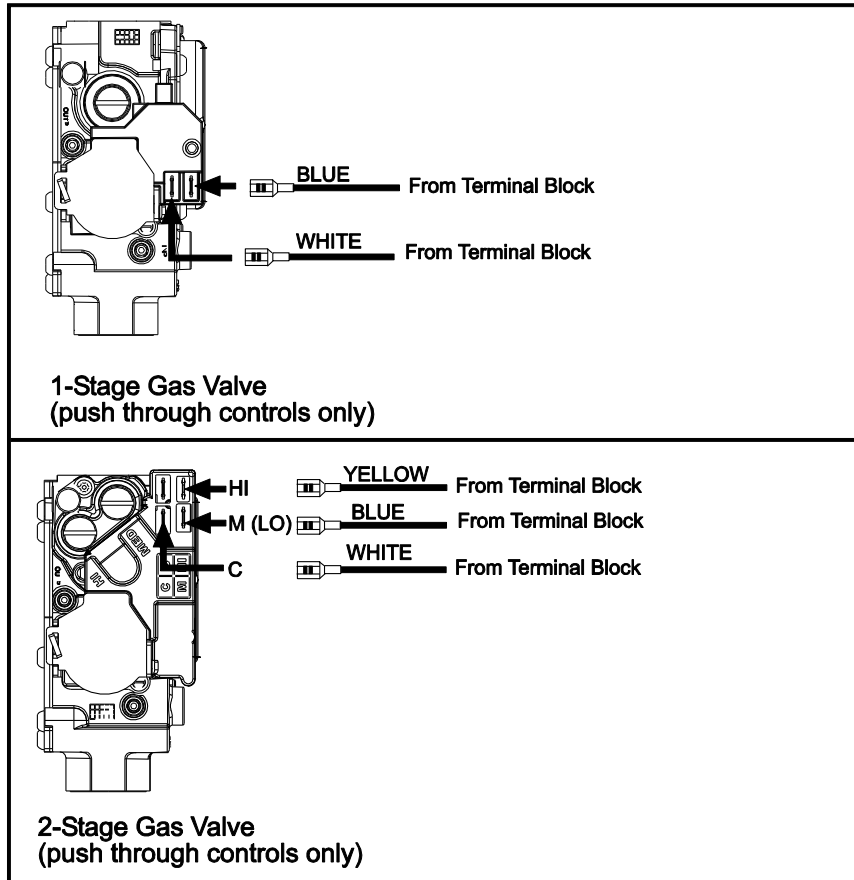

OUTLET GAS PRESSURE CHECK AND ADJUSTMENTS

Gauges that measure pressure in pounds per square inch are not accurate enough to measure or set the manifold pressure. All measurements **MUST BE** made when the heater and all other gas burning equipment that is connected to the gas supply system are operating at maximum capacity. The combination gas valve is factory set and should not need adjustment. If gas pressure adjustment is required, follow the instructions.

1. Turn off all electrical power to the system prior to connecting manometer hoses.
2. Turn the outlet pressure boss test screw (3/32" Hex allen wrench plug) in the center of the boss **not more than one turn counterclockwise**. Attach a 5/16" hose and manometer over the tapered outlet pressure boss on the valve (see figure below). If regulator needs to be adjusted, see instructions below.

To Adjust Regulator (1-stage gas valves):

1. Turn on power and energize the main gas valve. Remove regulator cover screw (see figure below). Turn regulator adjustment screw **clockwise** ↻ to increase pressure, or **counterclockwise** ↻ to decrease pressure. Replace regulator cover screw and tighten securely.

DO NOT EXCEED THE PRESSURES SHOWN IN THE GAS PRESSURE TABLE.

2. After testing pressure and adjusting the regulator, turn off all electrical power to the system, remove manometer hoses, turn outlet test screw (3/32" Hex) clockwise to seal pressure port. Tighten to 7 in-lb minimum. Turn on system power.

To Adjust Regulator (2-stage gas valves):

1. Turn on power and energize main gas valve solenoid. Do not energize the **HI** solenoid.
2. Remove regulator cover screw from the **low fire** outlet pressure regulator adjustment (see figure below) and turn screw clockwise ↻ to increase pressure, or counterclockwise ↻ to decrease pressure. Replace regulator cover screw and tighten securely.
3. Energize main gas valve solenoid as well as the **HI** terminal.
4. Remove regulator cover screw from the **high fire** outlet pressure regulator adjustment (see figure below) and turn screw clockwise ↻ to increase pressure, or counterclockwise ↻ to decrease pressure. Replace regulator cover screw and tighten securely.

DO NOT EXCEED THE PRESSURES SHOWN IN THE GAS PRESSURE TABLE.

5. After testing pressure and adjusting the regulator, turn off all electrical power to the system, remove manometer hoses, turn outlet test screw (3/32" Hex) clockwise to seal pressure port. Tighten to 7 in-lb minimum. Turn on system power.

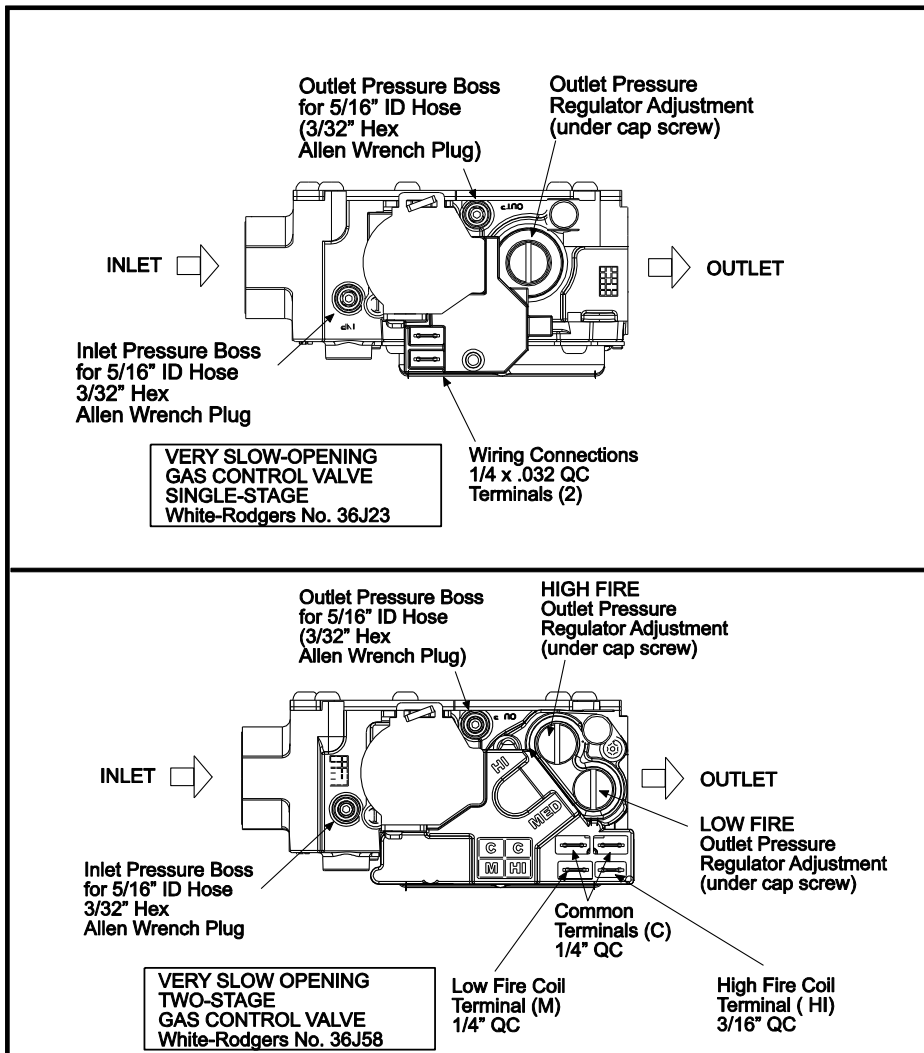

GAS PRESSURE TABLE				
GAS TYPE	MANIFOLD PRESSURE		SUPPLY PRESSURE	
	<i>High</i>	<i>Low (2-stage only)</i>	<i>Minimum*</i>	<i>Maximum</i>
Natural Gas	3.5" W.C.	1.4" W.C.	5" W.C.	14" W.C.
Propane Gas	10.0" W.C.	4.0" W.C.	11" W.C.	14" W.C.

GAS LEAK TEST

Perform the gas leak test using a leak detection solution or soapsuds solution at the orifices, pipe nipples and pressure boss screws or check by one of the methods listed in Appendix D of the National Fuel Gas Code, ANSI 2223.1-(latest edition). Bubbles forming indicate a gas leak. **SHUT OFF GAS AND FIX ALL LEAKS IMMEDIATELY.**

▲ WARNING:

**DO NOT OMIT THE GAS LEAK TEST.
DO NOT USE AN OPEN FLAME OF
ANY KIND TO TEST FOR LEAKS!**

COMPLETE KIT NUMBERS - GAS VALVE AND MANIFOLD ASSEMBLY REPLACEMENTS

Kit Part No.	Description	Burner Control Used On
44010370	Manifold with 1-Stage Nat Gas Valve #36J23-203B1	Control 20-200M BTU
44010380	Manifold with 1-Stage LP Gas Valve #36J23-204B1	Control 20-200M BTU
44010390	Manifold with 2-Stage Nat Gas Valve #36J58-201B1	Control 20-200M BTU
44010400	Manifold with 2-Stage LP Gas Valve #36J58-202B1	Control 20-200M BTU